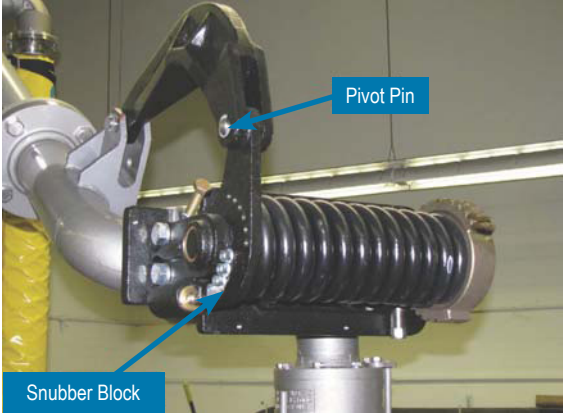
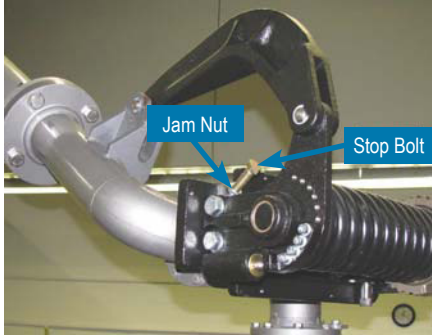

Travel Stop 788, 789, 790 Series

Upward	Downward
<p>Remove the (4) socket head screws in snubber block, then rotate snubber block toward pivot pin to allow for more upward travel or away from pivot pin for less upward travel. Replace the (4) screws and tighten.</p> 	<p>Loosen Jam Nut (located below lever arm) and turn stop bolt in for more downward travel or out for less downward travel. Then hold bolt and tighten jam nut securely.</p> 

Adjustment 788, 789 Series

NOTE: Left hand spring balance shown.
NOTE: The worm gear adjustment mechanism provides significant mechanical advantage during adjustment. Under high load conditions (790) it is recommended that the loading arm be raised to approximately 45° above horizontal. Under low load conditions it is possible to adjust the spring torque without raising/supporting the loading arm.

For more lifting action increase torque.
For less lifting action decrease torque.

1. Raise loading arm to highest position and secure.
2. Hold Adjusting Nut of Spring Regulator [2] with a large wrench.
3. Loosen lower Bolt of Spring Keeper and remove upper one. Using a large screwdriver push Spring Keeper forward. With Spring Keeper disengaged turn Spring Regulator Adjusting Nut clockwise for more or counter clockwise for less torque.
4. With spring tension in desired position press Spring Keeper back into position on Spring Regulator. While holding Spring Regulator Adjusting Nut, tighten Spring Keeper Bolts [3]. Be sure Lock Washers [4] are in place.
5. Minor adjustment can be achieved by turning the Spring Keeper ½ position. This is done by removing the 2 Keeper Bolts [3] and turning the Spring Keeper end for end, so that the “teeth” of the Spring Keeper will be reversed.

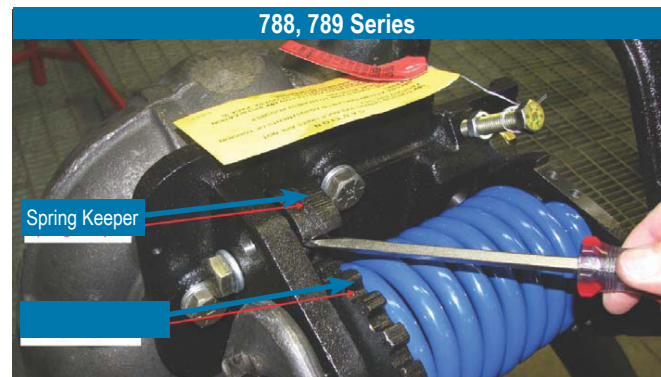

Parts List: 788, 789 Series Counterbalance

No.	Part	No.	Part
1	Torsion Spring	13	Snubber Block
2	Spring Regulator	14	Lock Washer
3	Bolt	15	Bolt
4	Lock Washer	16	Bolt
5	Spring Keeper	17	Nut
6	Spring Arm	18	Screw
7	Lever	19	Cover (NOT SHOWN)
8	E-ring	20	Spring Compression
9	Pin	21	Snubber Retainer
10	Support Bracket	22	Snubber Plunger
11	Bearing Flange	23	E-ring
12	Side Support	24	Pin

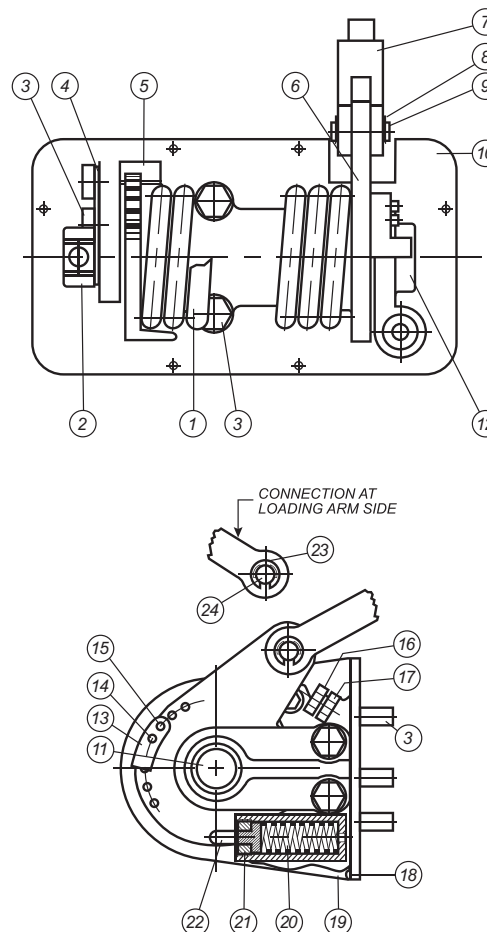

Maintenance 788, 789, 790 Series	
Lubrication	The torsion balance is provided with a self-lubricating Cylindrical Bearing. Only when operating under severe conditions, a little oil may be applied to Bearing [7]. Pins [13] on Spring Arm [23] and Link Arm [9] should have some oil quarterly.

Safety



Danger! Before performing any maintenance, always secure the Loading Arm and remove all tension from the counterbalance -- a torsion spring. The Loading Arm counterbalance spring contains a substantial amount of stored energy. You must relieve this energy before any disassembly. Failure to remove all tension from the counterbalance spring of the

Loading Arm before maintenance may cause serious personal injury or death.



WARNING! While installing and using the Loading Arm, always wear adequate personal protection, including hard hats, gloves, and steel-toed work boots. Failure to wear adequate personal protection may cause serious personal injury or death.



WARNING! Always follow the procedures prescribed in this Document. Failing to follow the procedures prescribed may damage the Loading Arm and cause serious personal injury or death. Consult Loading Arm Installation, Maintenance & Safety Manual for more details.