



OPW Installation and Maintenance Instructions

OPW 623V Pressure / Vacuum Vent Valve

IMPORTANT: Please read these warnings and use the assembly instructions completely and carefully before starting. Failure to do so may cause product failure, or result in environmental contamination due to liquid leakage into the soil, creating hazardous spill conditions.

IMPORTANT: The OPW 623V Pressure / Vacuum vent is pre-assembled for your convenience and ease of installation. Check to make sure the unit is intact and undamaged and all parts have been supplied. Never substitute parts for those supplied. Doing so may cause product failure.

WARNING-DANGER: Using electrically operated equipment near gasoline or gasoline vapors may result in a fire or explosion, causing personal injury and property damage. Be sure that the working area is free from such hazards, and always use proper precautions.

NOTE: At all times when product is in the storage tank keep the vent pipe capped, so the vapors cannot escape into the environment.

Notice: OPW products must be used in compliance with applicable federal, state, and local laws and regulations. Product selection should be based on physical specifications and limitations and compatibility with the environment and material to be handled. All illustrations and specifications in this literature are based on the latest production information available at the time of publication. Prices, materials, and specification are subject to change at any time, and models may be discontinued at any time, in either case, without notice or obligation.

Standard Product Warranty

OPW warrants that products sold by it are free from defects in materials and workmanship for a period of one year from the date of manufacture by OPW (ECO products two years from date of manufacture.) Proof of purchase may be required. As the exclusive remedy under this limited warranty, OPW, will at its sole discretion, repair, replace, or issue credit for future orders for any product that may prove defective within the one year date of manufacture period (repairs, replacements, or credits may be subject to prorated warranty for remainder of the original warranty period, complete proper warranty claim documentation required.) This warranty shall not apply to any product that has been altered in any way, which has been repaired by

any party other than a service representative authorized by OPW, or when failure is due to misuse, or improper installation or maintenance. OPW shall have no liability whatsoever for special, incidental or consequential damages to any party, and shall have no liability for the cost of labor, freight, excavation, clean up, downtime, removal, reinstallation, loss of profit, or any other cost or charges.

For any product certified to California 2001 standards, OPW warrants that product sold by it are free from defects in material and workmanship for a period of one year from date of manufacture or one year from date of registration of installation not to exceed 15 months from date of manufacture by OPW.

THIS WARRANTY IS IN LIEU OF ALL OTHER WARRANTIES, EXPRESS OR IMPLIED, AND SPECIFICALLY THE WARRANTIES OF MERCHANTABILITY AND FITNESS FOR A PARTICULAR PURPOSE. THERE ARE NO WARRANTIES, WHICH EXTEND BEYOND THE DESCRIPTION ON THE FACE HEREOF.

623V Series Performance Specifications:

This Pressure / Vacuum vent has been manufactured and tested to the following specifications: Pressure leak rate not to exceed 0.05 CFH at 2" W.C. Vacuum leak rate not to exceed 0.21 CFH at -4" W.C. The cracking pressure to be 2.5" to 6" W.C. and cracking vacuum to be -6 to -10" W.C. Tested using CARB Test Procedure TP-201.1E or applicable Phase I Executive Order.

Torque Specification:

Vent Assembly 2" NPT, 35 ft-lbs minimum to 55 ft-lbs maximum.

OPW 623V Pressure / Vacuum Vent Valve INSTALLATION INSTRUCTIONS:

Step 1.

Deburr and thoroughly clean vent pipe. Apply pipe dope to vent pipe threads. Pipe dope to be a non-hardening, gasoline resistant pipe thread seal compound.

Step 2: (See Figure 1)

Screw the vent assembly onto the vent pipe and torque to 35 ft.-lbs minimum to 55 ft.-lbs maximum. Use the flats on the pipe adaptor only, **Do not wrench on the composite valve assembly.**

NOTE: NEVER PAINT OR COVER THE VENT

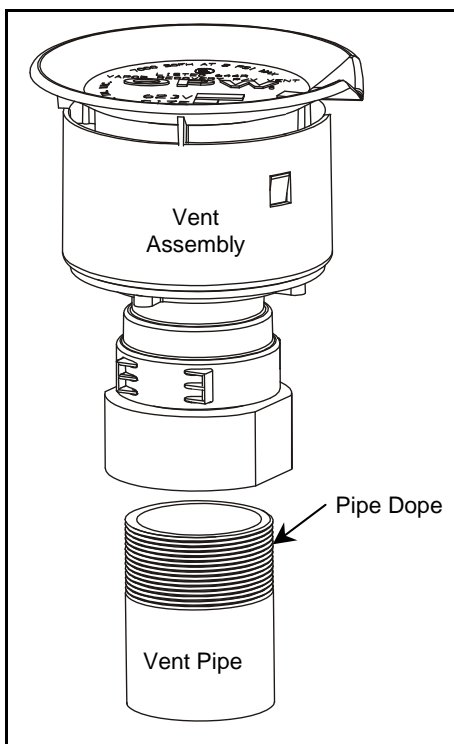

Figure 1

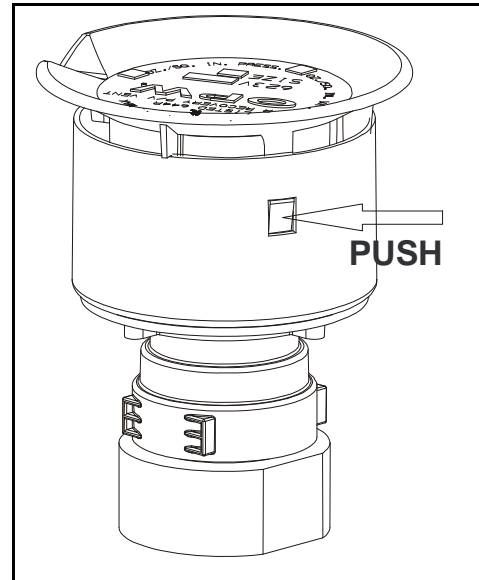

Figure 2

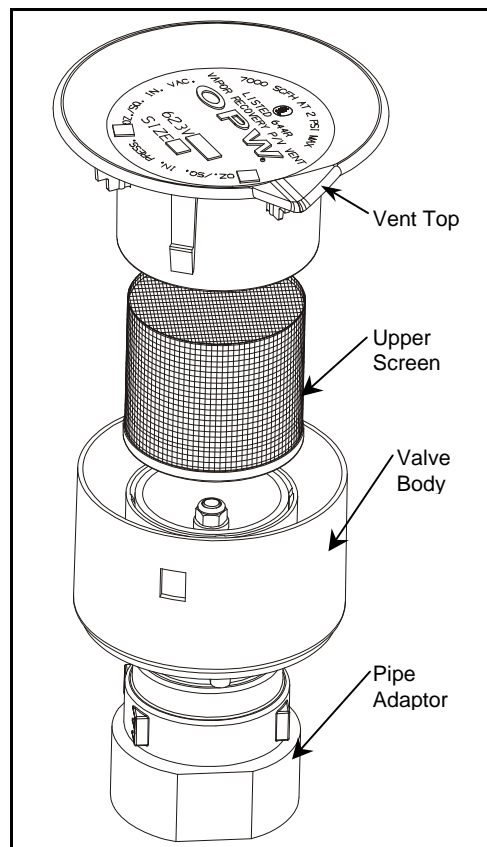

Figure 3

Operation and Maintenance:

Annual maintenance is required to keep the vent operating satisfactorily. Remove and inspect filter screens – clean or replace as necessary.

Upper Screen Maintenance

1. Remove vent top by depressing tabs as indicated in Fig. 2, and lift top upward. Screen will slip up and out of valve.
2. Clean or replace filter screen (P/N H14895M) as necessary and reinstall Fig. 3.
3. Reinstall vent top by reinserting into the body. Be sure the tabs are inside the valve body, and then rotate top until the tabs snap into place

Lower Screen Maintenance

Note: Do not remove the pipe adaptor from the vent pipe to service the lower filter screen.

1. Remove valve assembly from the pipe adaptor. Grip assembly at the flats just above the pipe adaptor and unscrew. (Fig. 4) Wrench C05102M can be used for this purpose.
2. Lift the filter screen out and clean or replace (P/N C05086M) as necessary.
3. Reinstall filter screen in the pipe adaptor (see Fig. 4 for orientation).
4. Reinstall valve assembly on pipe adaptor and tighten until it stops. Do not wrench valve assembly except with P/N C05102M

Important: Leave these instructions with Station Operator.

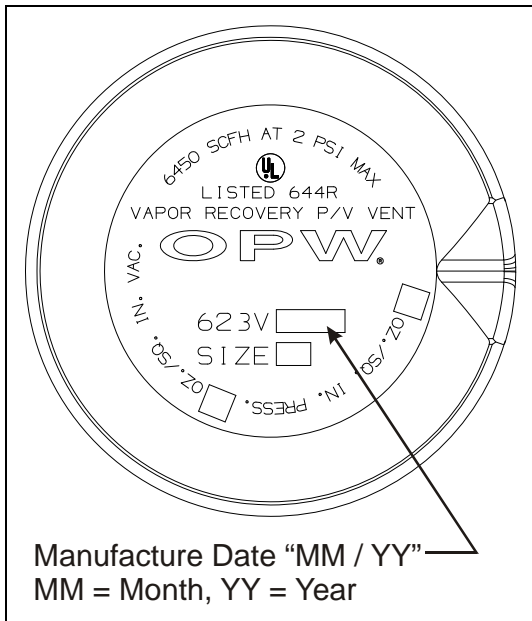

Product Identification

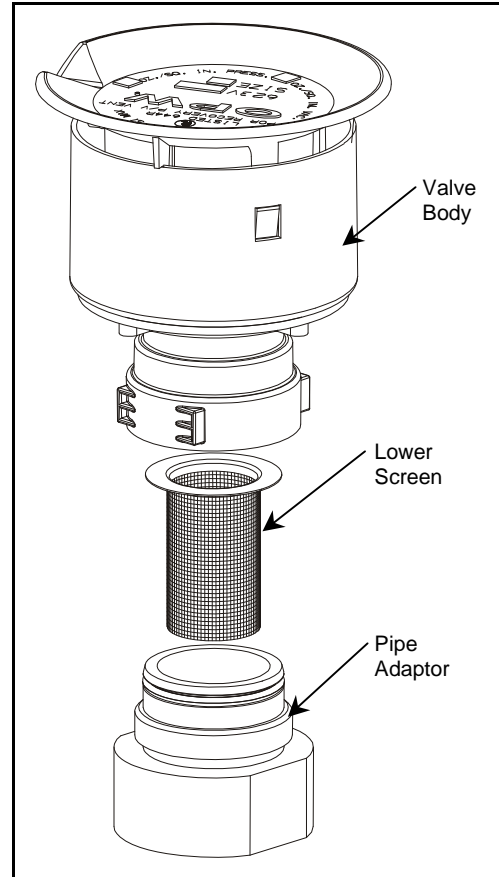

Figure 4



3250 US Highway 70 Business W.
Smithfield, North Carolina 27577
Customer Service: 1-800-422-2525
www.opwglobal.com